

MasterMover®

Worldwide Electric Tug Solutions



PS3000+

Power Steered

Power Steered PS3000+ The most powerful pedestrian electric tug offered by MasterMover is the PS3000+ which is capable of moving loads on castors up to 30,000 kg. A single operator can drive using a wireless transmitter to / *Wireless Controlled*

push, pull and manoeuvre loads aided by power steering, the only tug to boast this feature. A robust *Electric Tug* hydraulic mast and a coupling system provide maximum traction to the industrial drive wheel whilst the drive motor and side loading industrial capacity battery supply the power to move.

Industries

Suitable for use in a wide range of applications and sectors



Automotive and Commercial vehicles Equipment



Automotive and Commercial



Construction and Mining

Key Benefits

1 year full guarantee

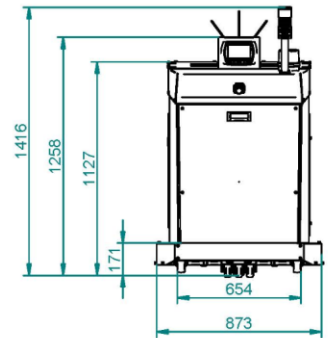
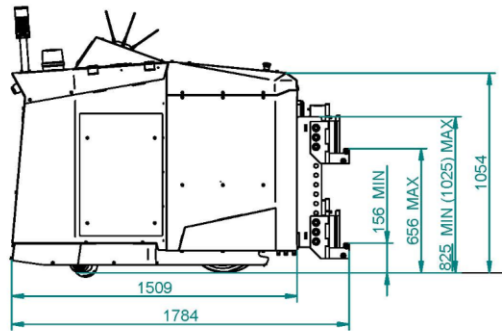
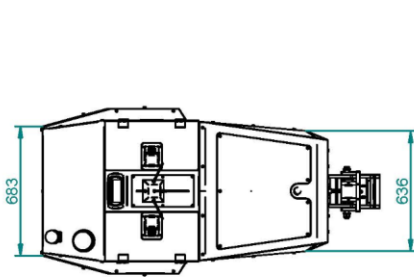

- Complete wireless control
- Hydraulic weight transfer
- Interchangeable batteries

- Up to 30,000kg load capacity
- Self adjusting hydraulics
- FEA tested steel chassis

Product Dimensions

Safety Features

See our website for full technical details

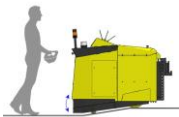

Self adjusting castor guard



Emergency stop



Warning horn

Max Load Weight

See our website for full technical details

*"Maximum load weight" is only a recommendation that we arrive at by estimating rolling resistance. Your environment and wheel type may affect this figure which is why we carry out a detailed technical evaluation on every project. All of our calculations include a "safe work load" factor to ensure safe operation in all circumstances.



Castors

Moves up to 30,000



Rails

Moves up to 120,000 kg*

kg*

PerformanceData

See our website for full technical details

Performance data

Product code	PS3000+
Recommended load weight - Castors	30,000 kg
Recommended load weight - Rails	120,000 kg
Machine weight including battery	1271 kg
Drive type	Electric AC
Parking brake	Electromagnetic
Drive wheel type	Polyurethane
Drive motor power	5 kW
Variable machine speed	0-6kph
Ingress Protection	IP44

Battery data

Battery pack - sealed - 120Ah 48V - interchangeable

Charging options

Charger - external - 20A 48V - 85V-265V

Charger - internal - 20A 48V - 85V-265V

Charger - battery station - 20A 48V - 85V-265V

Additional equipment

Option - single battery transportation trolley

Option - status light

Option - lifting and anchoring points

Option - on board camera

Option - battery protection system

Option - remote wireless E-stop - 1 machine

Male coupling options

Coupling - male - combi - extra large

Female coupling options

Coupling - female - extra large

ContactUs

Find your local dealer here

To arrange a demonstration, or for further information about our electric tug material handling solutions, please contact us

Airfield Industrial Estate, Moor Farm Road, Ashbourne, Derbyshire, DE6 1HD, United Kingdom

Telephone Sales: 01335 301 030 Email: sales@mastermover.com

Fax: Website: www.mastermover.com



About Us

Located in Derbyshire, the UK's manufacturing hub, MasterMover is a British business success story with customers all over the world.

Our products are relied upon by market leading organisations and global brands across a broad cross-section of industries including Aerospace, Automotive, Pharmaceutical, Retail and Healthcare.

